

# Installation, Operation and Maintenance Manual

## CPE1-STD



**PLEASE ENSURE THAT THIS INSTRUCTION  
IS PASSED ON TO THE USER OF THE UNIT**



### Contents:

### Page:

<b>Specification</b>	<b>2</b>
<b>Enclosure Dimensions</b>	<b>3</b>
<b>Customer connections and Internal wiring diagrams</b>	<b>5</b>
<b>Installation Instructions switch On and test procedure</b>	<b>6</b>
<b>Sensor Positioning</b>	<b>3</b>
<b>Performance Data</b>	<b>4</b>
<b>Fault Finding</b>	<b>6</b>
<b>Warnings</b>	<b>7</b>

### Your CPE 1 unit comprises the following:

- Fan Switch - Lit When On
- Heater Switch - Lit When On
- Temperature Set Dial
- Fan Fuse 5A
- Heater Fuse 5A
- Sensor with 10m of Twisted Pair Cable

## Index

<b>Specification</b>	<b>2</b>
<b>Enclosure Dimensions</b>	<b>3</b>
<b>Customer connections and Internal wiring diagrams</b>	<b>5</b>
<b>Installation Instructions switch On and test procedure</b>	<b>6</b>
<b>Sensor Positioning</b>	<b>3</b>
<b>Performance Data</b>	<b>4</b>
<b>Fault Finding</b>	<b>6</b>
<b>Warnings</b>	<b>7</b>

## Specification

One step electric heater control panel for up to 3.0kw of heating

- One step heater control up to 13 amps, 230 volts, 1 phase
- On/off switches for 230 volt, 1 phase fan and heater
- Heater and fan fuses
- Failure of the fan will deactivate heater
- External temperature dial, setting 0-40°C range
- Neons showing fan 'On', heater 'On'
- Duct sensor supplied complete with 10m of cable

## Enclosure and Dimensions

Each unit is supplied white painted steel enclosure. The finished product meets IP44. Units are suitable for internal use only.

### Standard Panel sizes

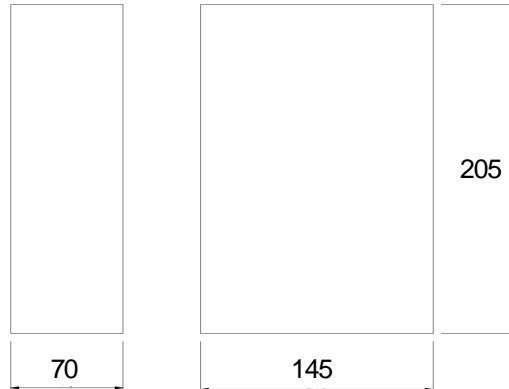

Store unit in a dry area. Maximum ambient 30°C

## Sensor Positioning

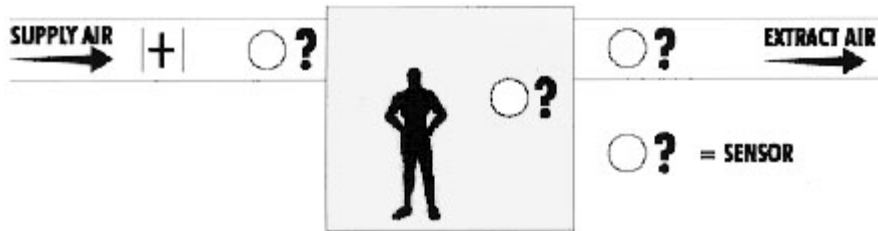

If the supply is for 'make up' air, with background heating in the area being served, then a duct sensor should be used. The sensor must be mounted in the supply duct away from the radiated heat.

The control panel will then maintain a constant duct air temperature, by switching the voltage feed to the heater battery steps. If the supply is for total area heating then a room sensor should be used. In some installations a duct sensor mounted in the extract/re-circulation air duct may also be used.

In this type of installation the system response time is very large and may cause the supply air to enter at very low or very high temperatures for some length of time.

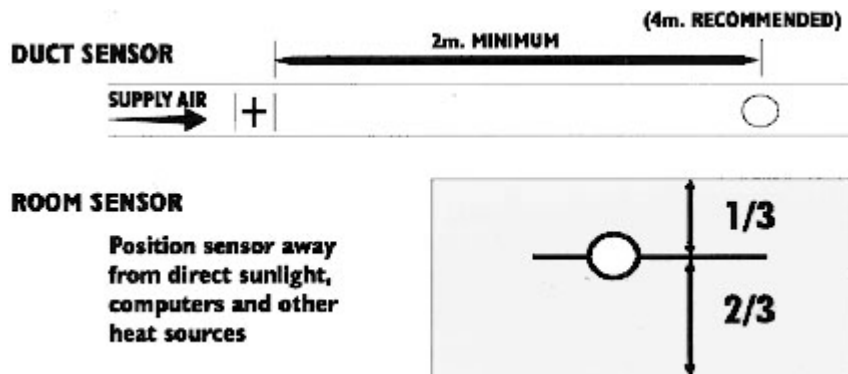

## Installation Instructions

Select a convenient dry position to mount the control panel to allow easy access for wiring and servicing, 50mm clearance should be left around the enclosure to allow for heat dissipation, ambient temperature should not exceed 30°C.

When using mineral insulated cable allow plenty of room for cable entry glands.

Ensure all swarf is removed from within the control panel before power is applied to the unit.

Wire up control panel in accordance with wiring diagram. Particular care must be taken to ensure all wiring complies with current IEE regulations and 'Health and Safety at Work Act'.

No modifications should be made without written authorisation from VES as this will invalidate the warranty.

## Performance Data

	CPE 1
Power Requirement	230 V 1ph 50Hz
Heater Max Load	3Kw
Steps of Heating	1
Supply Phase	1
Fuse Rating A	16 amps
Fan Phase	1ph
Fuse (Amps)	5
Sensor Type	DUCT(D)
Cable Length (M)	10 (Twisted Pair)
Max Cable Length (M)	30

To extend the sensor, screened cable or a twisted pair type 2187Y must be used.

## Sensor Characteristics

The sensor supplied is standard N.T.C non linear thermistor, nominally 4.7K ohms at 25°C (Measured out of circuit).

Temperature (°C)	Sensor Resistance (K OHMS)	Tolerance ( ) +/- 10%
0	18	10
10	10	10
20	6	10

## Panel Layout

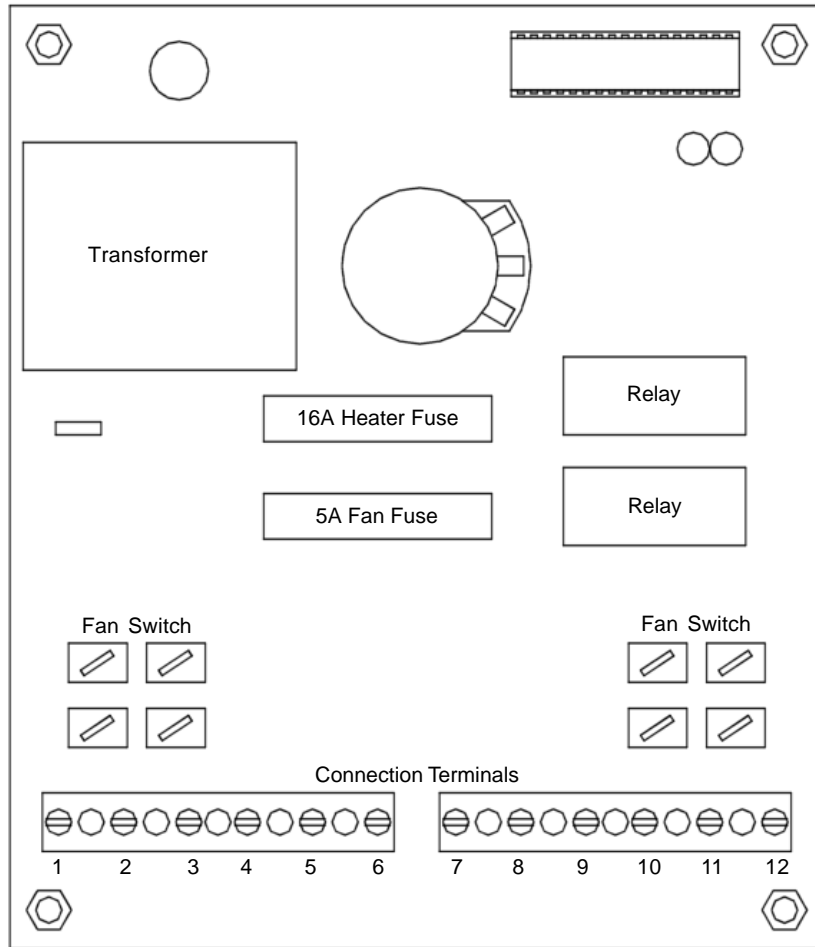

## Custom

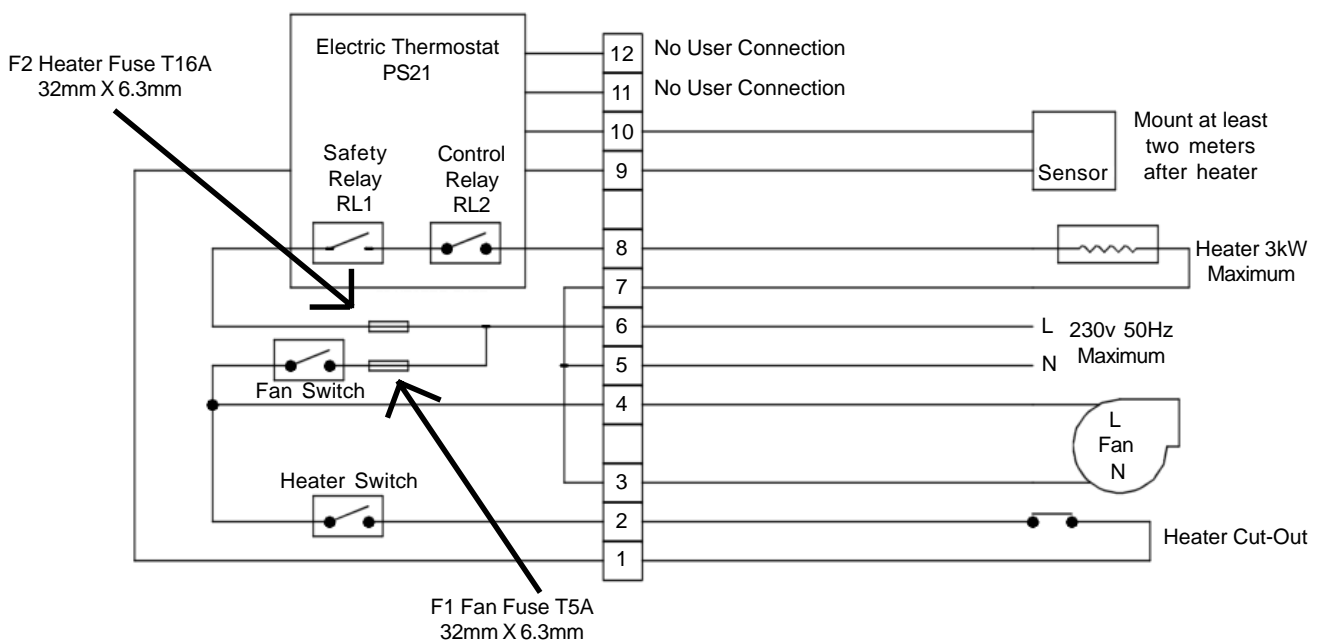

## Switch on and test procedure

### Before switch On:

- Check all interconnecting wiring is correct and strictly installed to IEE regulations
- Carry out safety checks and record results
- Where applicable check all safety cut-outs are correctly positioned and set
- Check sensor is correctly positioned (Refer to sensor positioning)
- Select control Temperature required
- Ensure all switches are 'Off' and fit the front panel.

### Switch On:

- 1 Turn fan switch 'On'
- 2 Fan 'Run' neon will light
- 3 Check fan rotation is correct and the correct airflow is obtained
- 4 Turn heater switch to 'On'
- 5 Heater neon will light
- 6 Ensure temperature rise across heater complies with design criteria

## Fault Finding

Problem	Cause	Action/Cure
Unit Not Functioning	No Supply Fan Fuse Blown	Check distribution board and local isolator. Replace Fuse
Fan Not Running	Not Switched On Fuse Blown Fan motor burnt out Not connected Local Isolator 'Off'	Switch 'On' Replace and Identify cause. Replace motor Check all wiring Switch 'On'
Heater not functioning	Heater not switched 'On' Fan not switched 'On' Thermal cut-out tripped (Manual) Airflow pressure switch (if fitted) not activated Heater not wired correctly Heater fuse blown Faulty control board	Switch 'On' Switch 'On' Reset and check reason for failure, refer to fault finding procedure Check switch position setting, wiring and airflow Check all wiring Replace and Identify cause Consult VES
Low heat output	Temperature set too low Incorrect sensor position Too much air Incorrect Heater Rating Faulty control board	Increase temperature setting Reposition Sensor Commission air volume Check design calculations Consult VES
Heater Thermal cut-put trips	Low/No airflow Filters Blocked Speed control set too low Duct work obstructed faulty trip	Change Filters Commission air volume Clear obstruction Remove, test and replace

## Warnings

Don't.....allow the air volume across the heater to fall too low. This information is provided with the order paperwork (also see below)

Don't.....short out the heater thermal cut-out or airflow pressure switch if fitted

Don't.....use standard or unsheathed wiring in the heater battery terminal box

Don't.....leave swarf in the panel

Don't.....omit the neutral feeds to the heater battery

Note: If the minimum air volume is not known, the following calculation may be used to obtain an approximate volume.

$$m^3/s = \frac{Kw}{49.2}$$

IF IN DOUBT, ASK ! - Telephone 08702 404340 and ask for the Service Department. The following Information will be usefull:

- 1 VES Sales order number
- 2 Control panel type
- 3 Nature of problem