

Installation, Operation and Maintenance Manual

CPE 2, 4, 6 & 9



**PLEASE ENSURE THAT THIS INSTRUCTION
 IS PASSED ON TO THE USER OF THE UNIT**



Contents:	Page:
Design, Concept and Operation	2
Enclosure and Dimensions	2
Installation Instructions	3
Sensor Positioning	3
Performance Data	4
Sensor Characteristics	4
CPE2	5
CPE4	6
CPE6	7
CPE9	8
Control Panel Options	9
Procedures	9
Fault Finding	10
Warnings	11

- Your CPE unit comprises the following:**
- Lockable Door Isolator
 - Panel Live Indication
 - Fan and Heater Switches
 - Fan Run and Trip Indication
 - Heater Run and Trip Indication
 - Internal Temperature Setting
 - MCBs for all Requirements
 - Sensor c/w 10M Cable

Index

Design, Concept and Operation	2
Enclosure and Dimensions	2
Installation Instructions	3
Sensor Positioning	3
Performance Data	4
Sensor Characteristics	4
CPE2	5
CPE4	6
CPE6	7
CPE9	8
Control Panel Options	9
Procedures	9
Fault Finding	10
Warnings	11

Design Concept and Operation

To compliment the extensive range of small air handlers supplied with electric heater batteries, the VES heater control package provides an efficient, cost effective and easy to install solution to heater control. They come complete and ready to install. All that is required is a mains supply and wiring to the heater battery, heater cut-out, sensor(supplied) and fan.

The basis to the control is a sophisticated step control circuit which varies the number of heater elements energised according to desired set point. The circuitry used is a well proven unit and incorporates the following features:

- Separate switches to provide isolation of fan and heater
- All outputs individually protected with M.C.B's
- Door isolator to ensure complete customer safety and ease installation. The door may be padlocked in the "off" position
- Fan run on timer interlocked to heater to maintain fan supply for approximately 110 seconds after switch off. This ensures all residual heat is dissipated from the heater
- Duct or room sensor supplied with 10 metres of cable
- Maximum load per step = 3KW
- Internal time clock or provision for 240V remote switching

Enclosure and Dimensions

Each unit is supplied in a steel enclosure with epoxy polyester powder coat finish in colour RAL 7032. The finished product meets IP44. **Units are suitable for internal use only.**

Standard Panel Sizes



	A	B	C
CPE2	150	400	500
CPE4	150	400	500
CPE6	150	400	500
CPE9	150	500	600

Installation Instructions

Select a convenient dry position to mount the control panel to allow easy access for wiring and servicing, 50mm clearance should be left around the enclosure to allow for heat dissipation, ambient temperature should not exceed 30°C.

When using mineral insulated cable allow plenty of room for cable entry glands. Fix enclosure to the wall, the gland plate at the bottom of the panel should be removed to allow holes for cable entry to be drilled.

Ensure all swarf is removed from within the control panel before power is applied to the unit.

Wire up control panel in accordance with enclosed wiring diagram. Particular care must be taken to ensure all wiring complies with current IEE regulations and Health and Safety at Work Act.

No modifications should be made without written authorisation from VES as this will invalidate the warranty.

Sensor Positioning

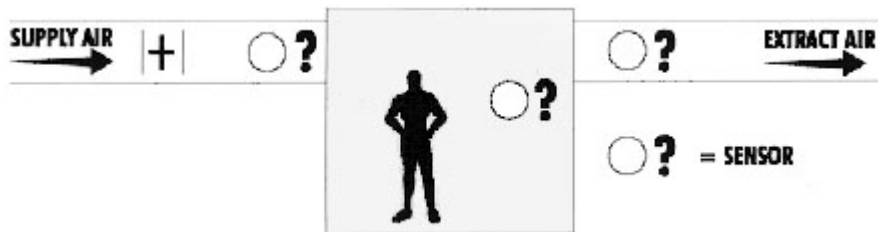

If the supply is for 'make up' air, with background heating in the area being served, then a duct sensor should be used. The sensor must be mounted in the supply duct away from radiated heat.

The control panel will then maintain a constant duct air temperature, by switching the voltage feed to the heater battery steps.

If the supply is for total area heating then a room sensor should be used. In some installations a duct sensor mounted in the extract/re-circulation air duct may also be used.

In this type of installation the system response time is very large and may cause the supply air to enter at a very low or very high temperatures for some length of time.

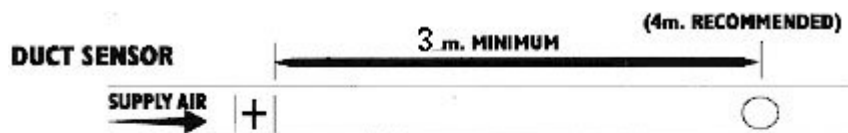

ROOM SENSOR
Position sensor away from direct sunlight, computers and other heat sources

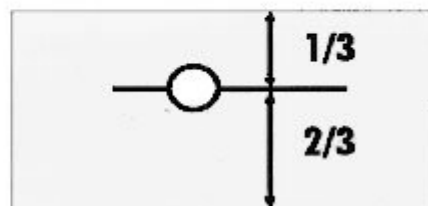

Performance Data

	CPE2	CPE4	CPE6	CPE9
Power Requirement	230V 1ph 50Hz	230V 1ph 50Hz 400V 3ph 50Hz	230V 1ph 50Hz 400V 3ph 50Hz	230V 1ph 50Hz 400V 3ph 50Hz
Heater max load	6Kw	12Kw	18Kw	27Kw
Steps of heating	2(Max) 2x1 phase	4(Max)	6(Max)	9(Max)
Supply phase*	1	1	1	1
Fan M.C.B	6 amps	10 amps	10 amps	25 amps MCB 8.5 overload
Fan phase	1 ph	1 ph	1 ph	1 ph
Run on timer +/- 20 seconds	120 Seconds	120 Seconds	120 Seconds	120 Seconds
Sensor type	Duct (D) or Room (R)	Duct (D) or Room (R)	Duct (D) or Room (R)	Duct (D) or Room (R)
Cable length (M)	10 (Twisted pair)	10 (Twisted pair)	10 (Twisted pair)	10 (Twisted pair)
Max cable length (M)	30	30	30	30

*Stepped over a 3 phase supply

To extend the sensor, screened cable or twisted pair type 2187Y must be used

Sensor Characteristics

The sensor supplied is standard N.T.C non linear thermistor, nominally 4.7K ohms at 25°C (measured out of circuit).

Temperature (°C)	Sensor Resistance (K Ohms)	Tolerance (+/- 10%)
0	18	10
10	10	10
20	6	10
30	3.7	10
40	2.3	10

CPE 2

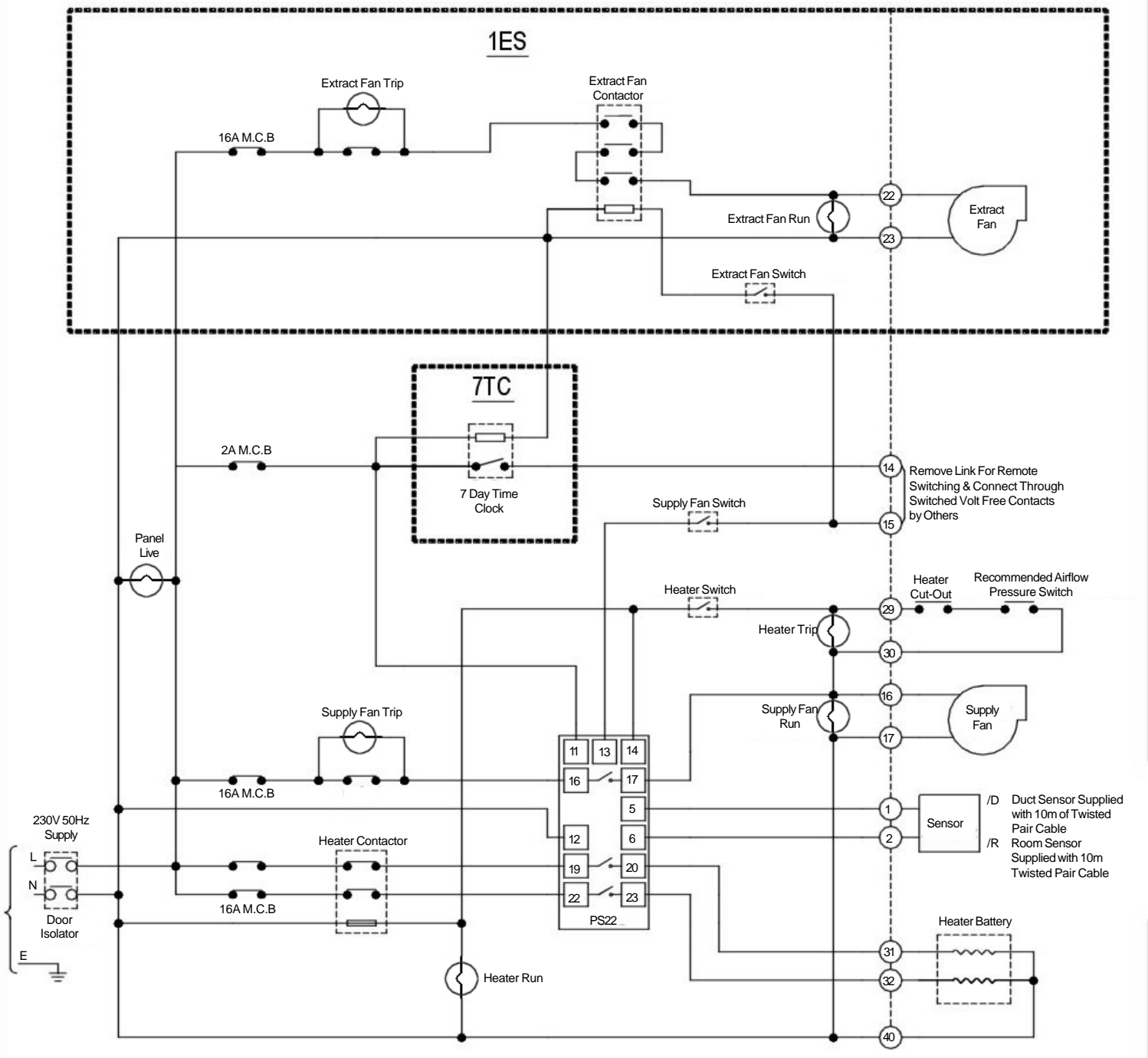

CPE 4

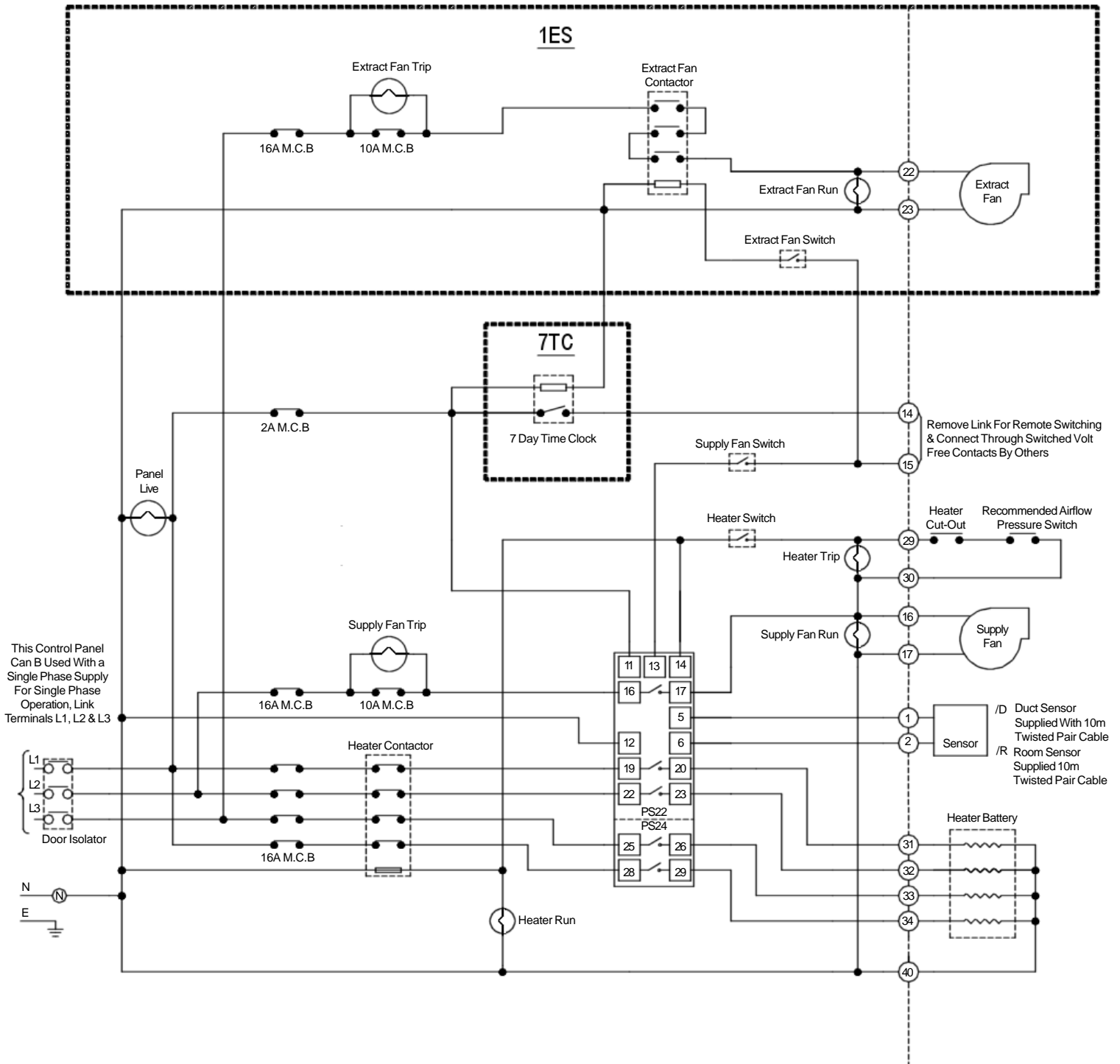

CPE 6

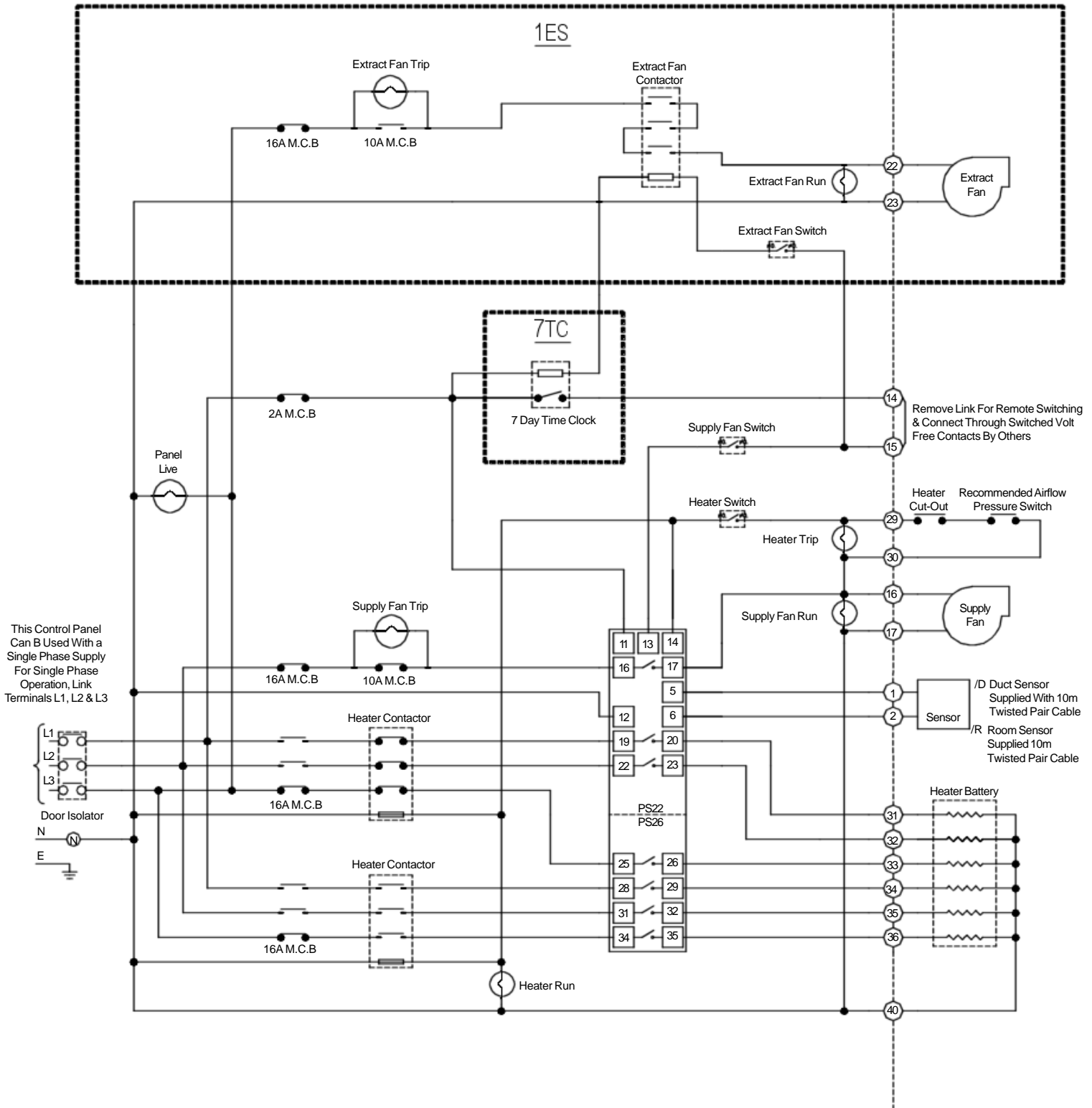

CPE 9

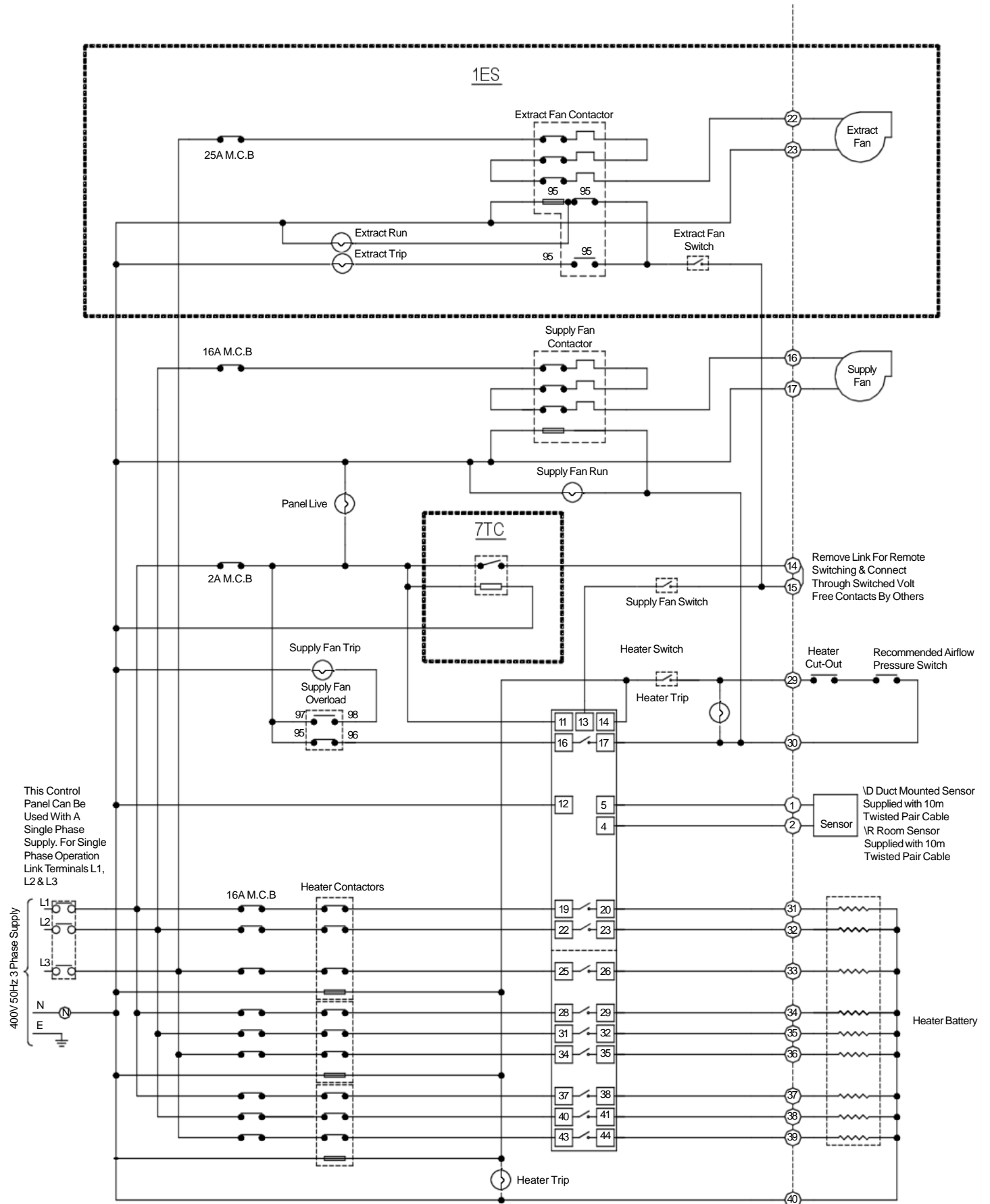

Control Panel Options

CPE(?) /STD /D	1ph Supply fan, Heater, Duct Sensor
CPE(?) /STD /R	1ph Supply fan, Heater, Room Sensor
CPE(?) /IES /D	1ph Supply fan, 1ph Extract fan, Heater, Duct sensor
CPE(?) /IES /7TC /D	1ph Supply fan, 1ph Extract fan, Heater, 7 Day time clock, Duct sensor
CPE(?) /7TC /D	1ph Supply fan, Heater, 7 Day time clock, Duct sensor

(?)	Model number
/ IES	1ph Extract fan
/ 7TC	7 Day time clock
/ R	Room sensor
/ D	Duct sensor

Note

Wiring diagrams show all options, connections are the same for all panels. When options are not required terminals are omitted.

Switch On and test procedure

Before Switch On.....

- Check all interconnecting wiring is correct and strictly installed to IEE regulations.
- Carry out electrical safety checks and record results
- Check all safety cut-outs are correctly positioned and set
- Check sensor is correctly positioned. (Refer to sensor positioning)
- Select control temperature required
- Ensure all switches are 'OFF' and close the door

Switch On.....

- 1 Turn door isolator to 'ON'
- 2 Panel live neon will light
- 3 Turn fan switch to 'ON'
- 4 Fan 'RUN' neon will light
- 5 Check fan rotation is correct and the correct airflow is obtained
- 6 Turn fan switch to 'OFF'
- 7 The fan will stop, run light will also go off
- 8 Turn fan switch to 'ON'
- 9 Turn heater switch to 'ON'
- 10 Heater neon will light.
- 11 Ensure temperature rise across heater complies with design criteria
- 12 Turn fan switch to 'OFF'(leave heater switch 'ON' to check interlock)
- 13 Heater will go OFF immediately
- 14 Fan will run on to dissipate any residual heat
- 15 Fan will remain 'ON' for approximately 110 seconds.

Fault Finding

Problem	Cause	Action/Cure
Unit Not Functioning	No supply	Check distribution board and local isolator
	Door open	Close door and switch isolator on
	Control MCB tripped	Reset MCB
Fan Not Running	Not switched on	Switch on
	MCB tripped	Identify cause, switch on
	Fan motor burnt out	Replace motor
	Not connected	Check all wiring
	Local isolator off	Switch on
Heater not functioning	Heater not switched on	Switch on
	Fan not switched on	Switch on
	Faulty neon	Replace
	Thermal cut-out tripped (manual)	Reset and check reason for failure, refer to fault finding procedure
	Airflow pressure switch not activated	Check switch position setting, wiring and airflow
	Heater MCB tripped	Identify cause and reset MCB
	Heater not wired correctly	Check all wiring
	Faulty control panel	Consult VES
Low heat output	Temperature set too low	Increase temperature setting
	Incorrect sensor position	Reposition sensor
	Too much air	Commission air volume
	Incorrect heating rating	Check design calculations
	Some heater MCB's tripped	Identify cause and reset
	Faulty control panel	Consult VES
Heater Thermal cut-out trips	Low/No airflow	Change filters
	Filters blocked	Change filters
	Speed control set too low	Commission air volume
	Ductwork obstructed	Clear obstruction
	Door isolator turned off before fan stops	It is unnecessary to turn door isolator off except for servicing
	Faulty trip	Remove, test and replace
Fan remains on when switched off at control panel	No fault	Fan will run on for approx 110 seconds to dissipate all residual heat
	Faulty run-on timer	Consult VES
Fan stops immediately when switched off at control panel	Run on timer only operates if heater has been selected	Consult VES
	Faulty run on timer	Consult VES

Warnings

Don't.....allow the air volume across the heater to fall too low. This information is provided with the order paperwork (also see below)

Don't.....short out the heater thermal cut-out or airflow pressure switch if fitted

Don't.....use standard or unsheathed wiring in the heater battery terminal box

Don't.....leave swarf in the panel

Don't.....omit the neutral feeds to the heater battery

Note: If the minimum air volume is not known, the following calculation may be used to obtain an approximate volume.

$$m^3/s = \frac{Kw}{49.2}$$

IF IN DOUBT, ASK ! - Telephone 08702 404340 and ask for the Service Department. The following information will be useful:

- 1 VES Sales order number
- 2 Control panel type
- 3 Nature of problem