

# CENTRETTE Roof Fan Units

Installation, Operation and maintenance Manual

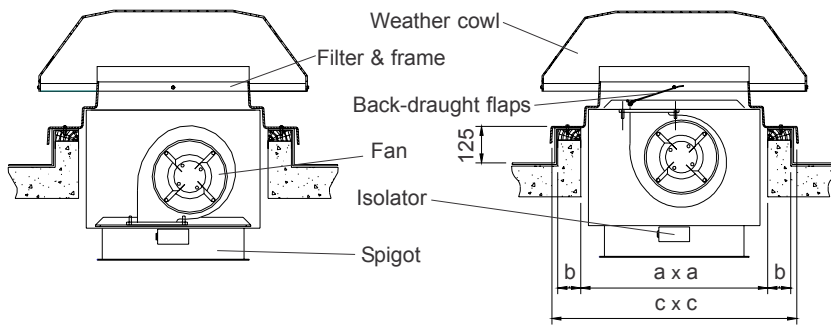

Fig.1 CTS (Supply unit)

Fig.2 CTE (Extract unit)

Unit size	a	b	c
CT1	330	35	446
CT2	457	50	610
CT3	610	75	840
CT4	730	75	925

Dimensions in millimetres

Fig. 3 Upstand dimensions

**IMPORTANT !**  
This manual must be read in full before Installation, Operation and Maintenance of the unit/s supplied

**IMPORTANT !**  
Do not use the GRP cowl or curb base for lifting the Centrette units

	Contents	page
1	Introduction	1
2	Installation	1
3	Wiring	2
4	Maintenance	3
5	Warranty	4
6	Declaration of Conformity	5

**Units with curb base mounting:**  
The CENTRETTE is designed to sit on top of a prepared roof upstand, the dimensions as shown in *fig.3*. Consideration should be given to the units position and we recommend that each unit be fixed to the upstand with coach screws or similar, via the pads provided on the curb base into the timber upstand see *fig.4*. This is especially important as the wind and elements may affect the unit's stability. A plastic washer or similar should be located between the G.R.P base and screw head, ensuring a seal against the weather. **DO NOT OVER TIGHTEN** these fixings since cracking of the base may subsequently occur and the seal formed by the washer made ineffective.

## 1 Introduction

The CENTRETTE is a range of supply or extract roof fan units, with a duty range of between 0.02 and 1.2m<sup>3</sup>/s. The unit offers a low profile when installed, a fitted isolator and flanged connection. The standard operating temperature of the unit is -20 to +40°C.

For further technical details contact VES on **08702 404340** quoting the sales order (SO) number and the unit type as found on the unit nameplate or visit **www.ves.co.uk**

## 2 Installation

The entire system must be considered for safety purposes and it is the responsibility of the installer to ensure that all of the equipment is installed in compliance with the manufacturer's recommendations, with due regard to the current HEALTH AND SAFETY AT WORK ACT and conforms to all relevant statutory regulations. Where a unit is installed so that a failure of components could result in injury to personnel, precautions should be taken to prevent such an injury.

**IMPORTANT !**  
Only experienced fitters should undertake this work. Take necessary safety precautions when working in elevated positions

Immediately upon receipt of goods, check for possible damage in transit paying particular attention to fan impellers, cracking of the GRP cowl and case. Prior to installation please check to ensure smooth rotation of the impellor after transit. Also check to ensure that any ancillary items are included. These will normally be supplied fitted or, in the case of small items taped to the unit.

In the event of any damage having occurred or if any item is found missing, it is essential to inform VES Andover Ltd. within **7 working days** of delivery quoting sales order (SO) number and the unit type as found on the unit nameplate. After this period we will be unable to accept any claim for damaged or missing goods.

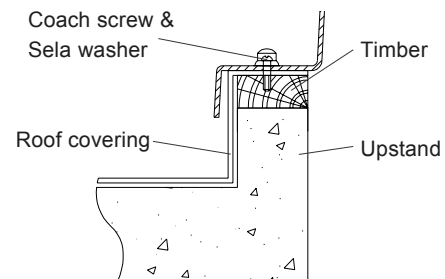

Fig.4 Typical curb base detail

Consideration must also be given by the installer for adequate illumination of the unit location in order for safe maintenance. Where provided, flanges and spigots should not be used to support the ductwork and used solely as a means of ductwork connection.

**Units with soaker sheet base mounting:**  
Before cutting into the roof ensure that the correct profile base has been purchased.

The CENTRETTE unit complete with soaker sheet is designed for sloping roofs only. It may not always be possible to install the units in their optimum position, however the following should be considered when positioning the unit:  
On existing roofs we recommend that the top edge of the soaker sheet be installed under the ridge capping, however good weather proofing can also be achieved further down the roof provided the soaker sheet top edge tucks under the existing roof panel see *fig.5*.

# CENTRETTE Roof Fan Units

Installation, Operation and maintenance Manual

## 2 Installation continued

### Ideal location

Where possible site the roof unit with the top edge of the soaker sheet placed under the ridge capping.

If a lower position is required tuck top edge of soaker sheet under desired roof panel to ensure weatherproofing.

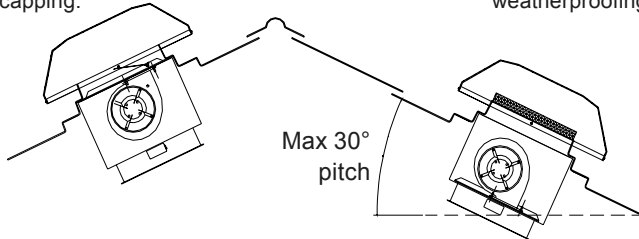

Fig.5 Recommended soaker sheet installation

On metal decking roofs, the roof sheets can be up to 8m long and are often riveted and or glued down. It is therefore impractical and unwise to attempt to lift these sheets and install the roof unit as described above. In these circumstances we recommend that a sufficiently sized hole be cut in the required location for the roof unit. The roof unit can then be positioned over the hole and fixed down by means of proper roofing bolts and sealed all round.

Once the unit is fixed into position a cover sheet can be run from the apex (under the ridge capping), down to and just overlapping the edge of the unit's soaker sheet. This ensures weatherproofing see fig.5.

### IMPORTANT !

When the unit is fitted to corrugated roofs, the unit must sit central to any one sheet and not where two sheets join together to ensure there is adequate support for the unit

**Please note:** If locating roof units in roof lights, trimmer supports may be required, taking into account that light restrictions will also occur. Care should be taken to avoid siting roof units directly above tie bars or purlins. This may obstruct the fan and reduce the unit performance.  
 N.B The maximum allowed roof pitch is 30°

## 3 Wiring

The CENTRETTE series contain a double inlet centrifugal fan, acting as either supply or extract roof units. All electrical connections to any unit must be carried out in accordance with the current edition of the I.E.E REGULATIONS and only competent electricians should be allowed to affect any electrical work to our units.

### IMPORTANT !

Do not connect any unit to an electrical supply voltage outside of that indicated on the motor nameplate

Each unit is pre-wired to a local isolator fitted to the spigot on the underside of the unit. The mains supply cable should be suitably sized and terminated as shown in fig. 4, electrical details are shown in fig.5.

### Standard fitted isolator arrangement

Fig.6 240v 1Ph 50Hz

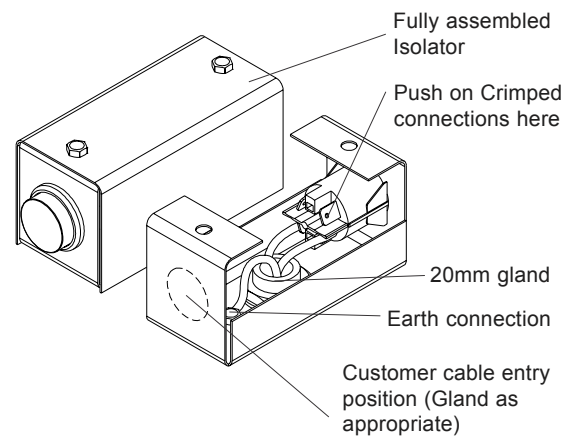
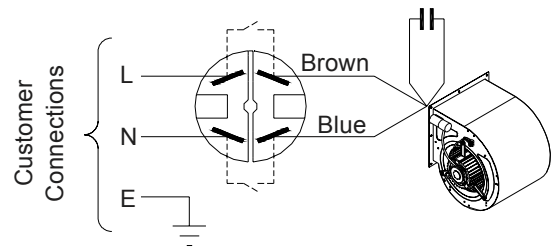

Model CTE/CTS	VES Fan Ref.	Motor Input (W)	FLC* (A)	Fan Speed (rpm)	Supply voltage
111	AL121	117	0.47	1590	230V 1Ph 50Hz
112	AL221	230	0.96	1365	230V 1Ph 50Hz
213	AL321	330	1.33	1945	230V 1Ph 50Hz
214	AL441	400	1.75	1280	230V 1Ph 50Hz
215	AL541	340	3.10	1380	230V 1Ph 50Hz
222	GZ241	245	1.20	1280	230V 1Ph 50Hz
315	AL541	698	3.33	1380	230V 1Ph 50Hz
323	GZ361	339	1.66	860	230V 1Ph 50Hz
324	GZ461	508	2.40	860	230V 1Ph 50Hz
326	GZ641	1115	4.90	1380	230V 1Ph 50Hz
425	GZ561	775	3.70	860	230V 1Ph 50Hz
426	GZ641	1260	5.55	1380	230V 1Ph 50Hz
427	GZ741	1780	6.80	1380	230V 1Ph 50Hz

FLC\* Full Load Current

Fig.7 Electrical Details

# CENTRETTE Roof Fan Units

Installation, Operation and maintenance Manual

## 4 Maintenance

### IMPORTANT !

Before attempting to carry out any work on our units, the unit **MUST BE COMPLETELY ISOLATED** from its electrical supply. Ensure a minimum of two minutes after electrical disconnection before commencing work. This will allow any moving part to come to a rest

In general, this series of units require very little maintenance. All fan and motor bearings are supplied fully greased, lubricated and sealed for life. In the unlikely event of component failure, spares are available from stock at VES Andover Ltd.

### IMPORTANT !

Before attempting to carry out maintenance work or repair work on our units, all accompanying documentation including warning labels on the unit must be referenced

### Recommended checks

Check inside the unit for an accumulation of dust, grease etc. If the fan impeller is heavily soiled, clean out carefully (ensure the unit is properly isolated). Failure to do this periodically could lead to a loss of performance or the fan to become out of balance, leading to bearing failure.

Fig.8 Access for filter maintenance

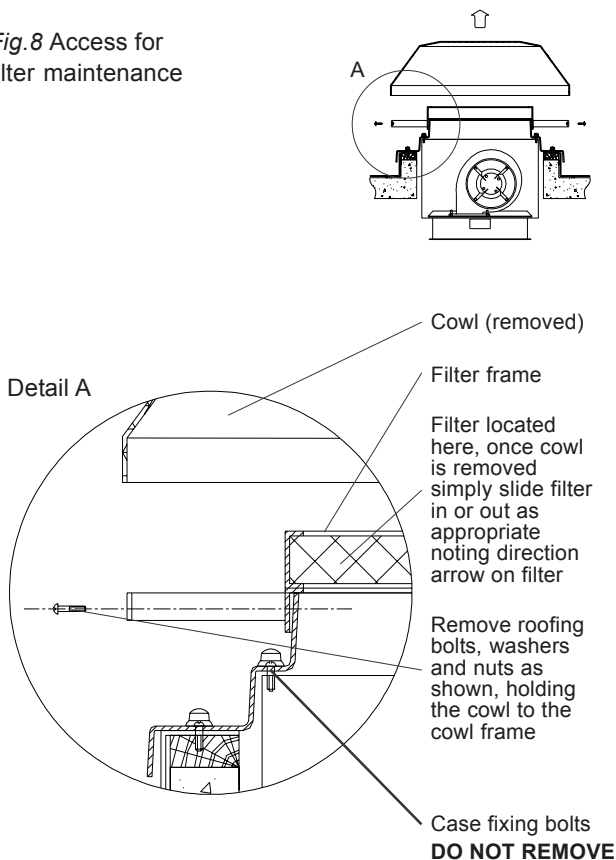

### Three Monthly Check

Clean under the cowl and around the bird mesh regularly to ensure performance is maintained. It may be necessary to remove the cowl to gain full access to the bird mesh: remove the four side fixings around the edge of the cowl and lift off as shown in *fig.8*.

CTS/F units are fitted with a disposable filter and these should be inspected regularly. If they are found to be heavily soiled or damaged they should be replaced immediately. To change the filter remove the cowl, again as shown in *fig.8*. The filter can then be slid out from the filter frame and replaced accordingly, taking note of the airflow direction arrow on the filter casing.

CTE units are fitted with back draught shutters and should be inspected to ensure they are operating smoothly and are intact. Clean or replace if necessary. Again as above, the cowl must first be removed to gain access to the back draught flaps.

Check G.R.P bases for signs of cracks or the possibility of water leakage. Paying particular attention around the securing bolts on the curb base. Replace as necessary.

### IMPORTANT !

It is critical that after any maintenance work has been conducted that all components removed/replaced be refitted correctly by a competent engineer

### WEEE Directive



At the end of their useful life the packaging and product should be disposed of via a suitable recycling centre. Do not dispose of with normal household waste. Do not burn

When enquiring after or ordering spares contact VES Spares Department, quoting the sales order (SO) number and unit type as found on the unit nameplate.

Telephone	08702 40 43 40
Fax	08702 40 45 50



**PLEASE ENSURE THAT THIS DOCUMENT IS PASSED ON TO THE END USER.**

We reserve the right to alter the specification without notice

©VES Andover Ltd. 2006

No part of this publication may be photocopied or otherwise reproduced without the prior permission in writing of VES Andover Ltd.



# CENTRETTE Roof Fan Units

Installation, Operation and maintenance Manual

## 5 Warranty

### Extended Warranties

All VES Andover Products come with a one year guarantee from date of dispatch, which covers parts and labour. You can now extend this with the following options:

#### Option 1. **FREE extended Warranty**

We can offer you a maintenance agreement that keeps this equipment in tip-top condition. If you take out this agreement, we will extend the warranty **free of charge for up to 5 years**, providing the regular maintenance agreement remains in place.

#### Option 2. **12-24 Month Extended Warranty**

12-24 months from the date of dispatch. This can be covered at a cost of just 3% of order value. (minimum charge £50.00).

#### Option 3. **12-36 Month Extended Warranty**

12-36 months from date of dispatch. For this cover, the charge is 6% of order value (Minimum charge £80)

Please State which option you require when you place your order. A transferable certificate will then be issued to you. *Please note, this offer excludes condensing units. We would be happy to quote you for these separately.*

### **Register for separate spares reminders and get a 10% discount**

Register for this free service and we will automatically send you a regular reminder detailing the consumable spares for this unit, together with their current list prices.

**You will then be entitled to a 10% discount off any spares.**

To arrange any of these options.

**or**      **Phone:**      **023 8046 1150**  
             **Email:**        **spares@ves.co.uk**

Stating the sales order and reference number from the unit.



# CENTRETTE Roof Fan Units

Installation, Operation and maintenance Manual



## *Declaration of Conformity*

Date: 29th February 2004  
Product: CENTRETTE – Roof Fan Units  
Type: CTE, CTS  
Manufacturer: VES Andover Limited

The product above is produced in accordance with EC Council Directives:

98/37/EC (Machinery Directive)  
89/336/EEC and amendment 92/31/EEC (Electromagnetic Compatibility Directive)  
73/223/EEC and amendment 93/68/EEC (Low Voltage Directive)

The European Harmonised Standards applied are:

BS EN ISO 12100, EN 294, EN61000, EN 60204-1

The National Standards applied in particular are :

BS 848 Part 1

Basis of Self attestation:

Quality Assurance to ISO 9001-2000, BSI Reg. Firm Cert. No. Q5375

Signature of Manufacturer:

Position of Signatory:

Technical Director